

Project IDE and JTAG debugger for the MSP430 microcontrollers

- Supports entire MSP430 family and future derivatives*
- The Project-430 IDE, MCA-430 macro assembler and PDS-430 command set simulator are supplied without charge *
- Integrates MCC-430 C compiler from MicroCOSM-ST or EW-430 C compiler from the IAR Systems, and provides project management and source-level debugging for applications written with these compilers (other compilers will be supported in future)
- Provides in-system flash programming, real-time run and single step program execution, breakpoints, and real-time tracing (tracing is available for selected derivatives only)
- High-level steps for C programs and low-level steps for assembly code
- Up to 8 unconditional breakpoints at an address, or a range of addresses, in code memory
- Up to 8 complex breakpoints/triggers on access to “bus events” and “register writes” which can be logically ORed, ANDed or sequentially programmed to break emulation or to trigger trace recording
- Enables examination and modification of internal resources of the target MSP430 MCU when execution is stopped
- For some MSP430 derivatives, the internal clock can be enabled after the break, so that the target MCU will continue to generate clocks for an external LCD or other peripherals
- The trace buffer records 40-bit frames displaying real-time signals on the internal MSP430 bus: there are 16 lines of address, 16 lines of data and 8 controls
- The depth of the trace buffer is defined by the particular type of MSP430 device (8 frames min)
- Ability to filter the trace and to search trace frames
- Several tracing modes: forward (start on trigger, stop on the buffer overflow), reverse (start on command, stop on trigger) and dynamical (start on one trigger, stop on another)
- The target MCU status can be monitored on-the-fly without stopping real-time execution
- TI MSP430 Flash Emulation Tool (MSP-FET430) can be connect to the IDE as an alternative JTAG debugger
- Works under control of Windows 9x/ME/2000/XP
- Communicates to a PC via a USB 1.1 interface

* Visit <http://www.phyton.com> to get the newest software update and list of supported devices

** Tracing is available only for a limited number of the MSP430 derivatives

© Copyright 2003, Phyton, Inc. Microsystems and Development Tools.
All rights reserved.

Phyton offers a complete development tool solution for the MSP430 microcontrollers produced by Texas Instruments

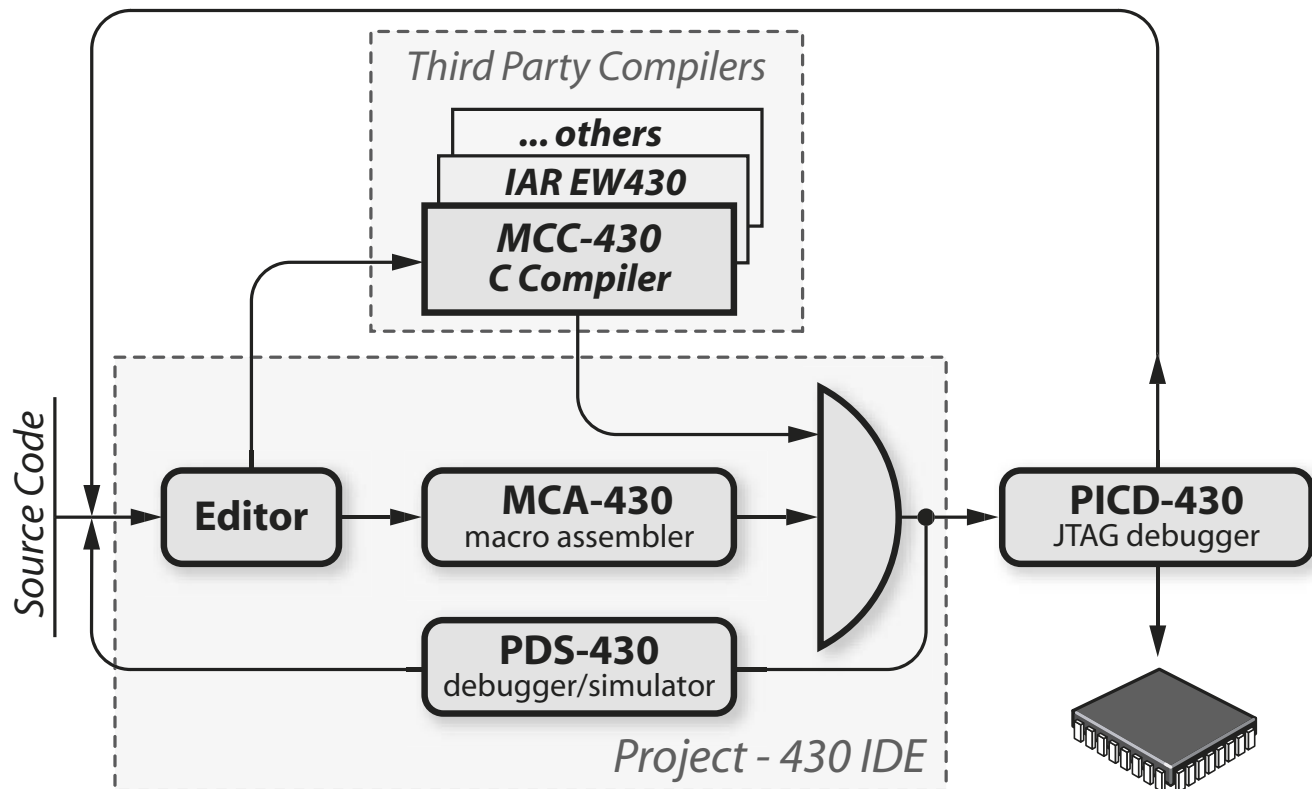

A full Project-430 package includes the MCC-430 C compiler (or the IAR MSP430 C compiler), MCA-430 macro assembler, PDS-430 command set debugger/simulator and PICD-430 in-circuit JTAG debugger integrated under control of the project IDE. Instead of the Phyton PICD-430 debugger the IDE can integrate a very popular TI MSP430 Flash Emulation Tool (MSP-FET430). This tool set provides a complete development cycle, from editing source texts to getting debugged code burned into the target microcontroller.